

TARIFF STRUCTURE BASED ON A NEW DEFINITION OF CUSTOMER RESPONSIBILITY IN POWER DISTRIBUTION SYSTEMS

Fabio Sismotto EL HAGE
Daimon Engenharia e Sistemas – Brazil
fabioseh@gmail.com

Nelson KAGAN
University of Sao Paulo - Brazil
nelsonk@pea.usp.br

ABSTRACT

Within a structured methodology, this paper presents a new definition of customer responsibility concerning the Brazilian electrical distribution tariff framework, which is essential for the division of the utilities' permitted revenue among customer types and voltage levels.

A new concept of load typology will be proposed, based on a hierarchical method that uses multiple statistical correlations between samples of load curves to determine "strong" profiles for customers and for network buses, which are represented by the resulting clusters of load curves. The representative load profile of each cluster will be based on a maximum correlation curve, obtained through an optimization algorithm that considers energy balance restrictions.

In this context, a new definition of customer responsibility will be suggested too, regarding the probabilistic association of customer-type load curves to the network load profiles considering the normalization of capacity costs per observed load peaks at each voltage level.

INTRODUCTION

During the last decades, since electricity distribution has become a permitted service under public regulation in several countries, the determination of a fair and efficient tariff structure, reflecting the appropriate costs of service, has been a detailed and intricate problem.

Some regulatory models concerning public tariffs and prices have emerged since public reforms of natural monopolies have taken place. Mainly though, there are three regulation models that could be cited as most frequently used, which are: Cost-of-service regulation, marginal cost and price-cap regulation [1].

Additionally, some endogenous mechanisms have been developed with the purpose of improving efficiency through the promotion of incentives to cost reduction. Yardstick competition [2] is one of the most used of these mechanisms, and it is related to the simulation of a virtual competitive utility, with more competitive operational costs and adequate service quality.

Under the price-cap regulation model associated with the yardstick competition mechanism [3], the Brazilian Electricity Regulatory Agency has been able to determine both the permitted revenue and the electrical tariff level, which will depend also on the energy market.

Since the level of prices can be determined through the quotient of revenue and energy market, the tariff structure must indicate how the utility's permitted revenue must be divided among customer types and voltage levels.

Unlike the Ramsey pricing approach [1] [4] where social welfare must be maximized based on estimated demand curves of groups of customers, the Brazilian tariff structure will be independent of customers' elasticity of demand, but it will rather depend on its responsibility on marginal expansion and operational costs.

Since the Brazilian Agency has been using a consolidated methodology for designing the tariff structure regarding the usage of the electrical distribution network, some issues have emerged, such as the absence of normalized capacity costs and the use of poor classification methods for identifying representative customers' load profiles.

The main approach to be presented in this paper will be the concern with the representation of customers' profiles associated with their responsibilities on the usage of the distribution system, aiming at a simple and efficient tariff structure.

MARGINAL COSTS

From the economic theory, in a perfectly competitive market, prices will be naturally set equal to marginal costs of production, and, considering the absence of externalities, social welfare will be maximized [5].

On the other hand, under monopolistic markets, prices will be set above marginal costs as a result of the company's power over customers, and this will create a social deadweight loss as customer's surplus will be transferred to producer.

In the attempt to minimize loss of social welfare, the regulatory authority must set monopoly prices as close as possible to the marginal costs of production, trying this way to promote a simulated competitive and efficient market.

In an analogous approach, for the energy distribution sector, the long run marginal costs represent a cost estimate for supplying an additional demand unit (1 kW) at the system peak hour, which will be calculated in \$/kW year (Currency per kilowatt-year).

Under the price-cap regulation model, the utility's revenue is generally determined regardless of marginal costs, what makes the tariff structure – the differences in prices for tariff modalities – the mechanism in which the marginal costs concept will be accomplished.

This means that although the level of prices shall not depend directly on marginal costs, tariff structure will, and this assures to customers an appropriate economic signal, due to differences in consumers types and levels of voltage for energy delivery.

There are several methods [6] for determining the long run marginal costs for the energy distribution service, but it is not the purpose of this article to describe or analyse them. In the presented study, the marginal costs per voltage level will be considered as given by the regulatory authority or by the

distribution utility.

CUSTOMER REPRESENTATION

The customer representation is crucial for determining its appropriate responsibility in the usage of the electrical power network, and, as tariffs must last in Brazil for at least a year, this representation must be a typical one (the most frequent).

In this context, load curves for medium and low voltage level customers are generally obtained through statistical samples of customers randomly chosen in the utility's concession area. For each customer, several days of power measurement are needed to represent each load profile, which will result in thousands of load curves to be analyzed and classified before determining cost causation responsibilities.

Customers must be grouped by class and level of voltage, which will guarantee, for example, that all residential customers connected in the low voltage level will be analysed together, since a representative profile must emerge from this group.

For each customer, three load curves must be chosen among several days of measurement, namely one representing a working day, one for Saturdays and one for Sundays. The chosen load curves must be the most frequent ones, since they will represent a typical load profile for each sampled customer.

The proposed classification method considers that two load curves are similar if they have a high statistical correlation between them. The consideration of the statistical correlation, instead of the usual Euclidean Distance [7], has shown to be more effective since the range in which similarity is measured varies from -1 to 1.

For example, in figure 1 it is possible to comprehend the considered range variation for measuring the profile similarity between two load curves.

Figure 1 – Statistical correlation range between two load curves

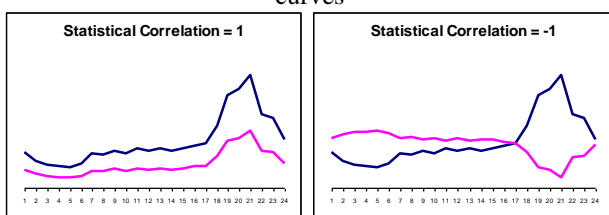

The statistical correlation between two data series (in this case, a data series is a 24-hour load curve) is given by equation 1:

$$Corr(C_1, C_2) = \frac{Cov(C_1, C_2)}{\sigma_{C1} \cdot \sigma_{C2}} \quad (1)$$

Where $Cov(C_1, C_2)$ is the covariance between the two load curves and σ_{C1} and σ_{C2} are the standard errors of each load curve.

The algorithm for classifying similar customer profiles is presented in figure 2. In this algorithm, a cluster is a data set that contains grouped load curves, and the resulting representative curve of a cluster is obtained through an optimization algorithm in which a Maximum Correlation Curve (C_x) is calculated under daily energy restrictions. For simplification, all load curve points are divided by its daily average demands and presented in a per-unit basis, which implies that daily energy will be always 24 Wh. The optimization algorithm that calculates the Maximum Correlation Curve is as follows:

$$Max [Corr(C_x, C_1) + Corr(C_x, C_2) + \dots + Corr(C_x, C_n)]$$

subject to

$$\sum_{i=1}^{24} C_{xi} = 24$$

$$Corr(C_i, C_j) = \frac{Cov(C_i, C_j)}{\sigma_{Ci} \cdot \sigma_{Cj}}$$

Where

C_i – Load Curve of customer i

C_x – Maximum correlation curve of the cluster

Figure 2 – Load Curves Classification Algorithm

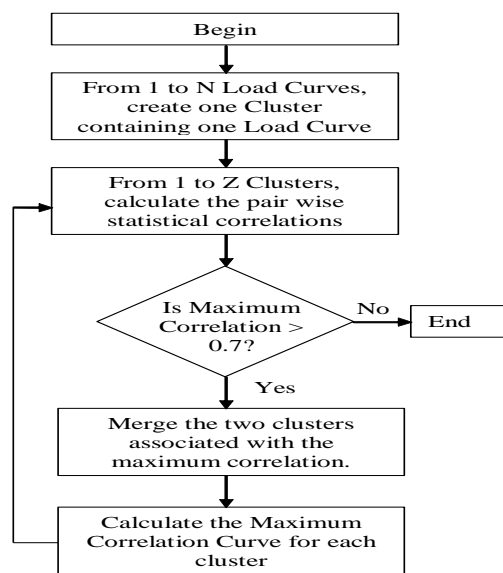

Using the presented algorithm in a real case for the classification of 143 rural customers, with an average monthly consumption level between 0 and 200 kWh, the number of resulting clusters was 33, one of them with a market share of 67%, containing 94 load curves.

Using the traditional k-means method with Euclidian distance to measure similarities, these 143 load curves were grouped into 106 clusters, and the most representative one

contains only 10 load curves, with a 6.98% market share. The results are promising, especially considering the simplicity and efficiency of the proposed algorithm. It is important to remark that the only parameter to be set before classification is the minimum correlation required for cluster formation.

CUSTOMER RESPONSIBILITY

Since there are different tariff modalities that depend on the type of the customer and on the level of voltage in which it is connected, it is necessary to quantify these differences in order to establish a proper tariff structure.

The present study will consider that energy consumers have a very low price elasticity of demand, what means that they are quite insensitive to price changes. One could say that it is not true for industrial or even commercial customers, but due to the absence of more precise information in Brazil, and to the complexity of acquiring data for the determination of customers' price elasticity of demand, it will be considered zero.

In this way, the key question to be asked when trying to establish different prices for different users is how each customer-type affects, in average, the aggregate load demand of the whole distribution system?

To answer this question, it is necessary to know how the customer-type profile interacts with load profiles observed in power transformers that feed distribution networks in which the customer is connected (network-type).

Instead of a nodal approach, what is to be considered here is similar to the one approach followed by the Brazilian Regulatory Agency, which takes into account customers generally represented by a sample of load profiles, as well as a simplified distribution system diagram, containing for each existing level of voltage, the customer-type and the network-type load profiles.

Figure 3 shows an example of a simplified distribution system diagram, with two network-type load profiles representing transformations between two voltage levels, as well as three customer-type load profiles, hypothetically representing three tariff modalities.

Figure 3 – Simplified distribution system diagram

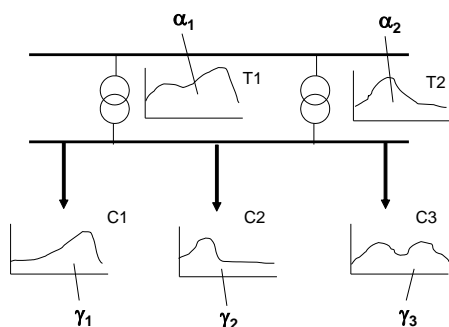

As customer-type and network-type load profiles were

obtained through statistical samples from the electrical power distribution system. It is assumed that they are statistically representative and it is necessary to determine how customer-types will combine to form network-type load profiles.

In figure 3 the “ α ” variables represent the market share of each network-type load profile, as well as the “ γ ” variables represent the market share of each customer-type load profile. The market shares of networks and customers can be mathematically understood as the probabilities of the existence of such profiles in the system.

Considering, in the example of figure 3, that a customer-type can be fed by any network-type, it is necessary to formulate a mathematical problem in which the “ π ” variables will be determined.

Figure 4 illustrates the definition of the “ π ” variables, which are defined as a two-dimensional probability that indicates how a customer-type will be fed by a network-type load profile.

Figure 4 – Definition of the “ π ” variables

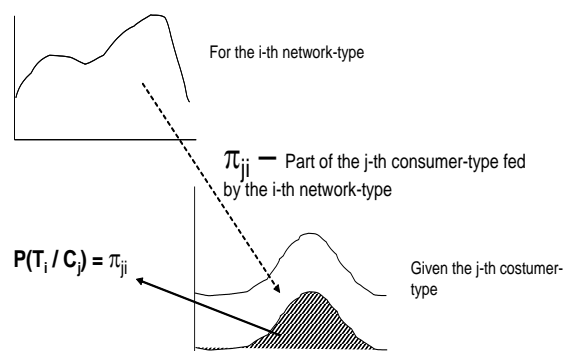

The “ π ” variables can be mathematically understood as the conditional probability of the existence of the i^{th} network-type, given the existence of the j^{th} customer-type.

Given such premises, the problem to be solved for each network-type load profile is:

$$Max \sum_{i=1}^m Corr[T_i(t), \theta_i(t)]$$

Subject to

$$\sum_{i=1}^m \pi_{ji} = 1; \sum_{i=1}^m \alpha_i = 1; \sum_{j=1}^{tc} \gamma_j = 1$$

Where

$$\theta_i(t) = \sum_j \pi_{ji} \cdot C_j(t)$$

- tn: Total network-type load curves
- tc: Total customer-type load curves
- α_i : Market share of the i^{th} network-type load curve
- γ_j : Market share of the j^{th} customer-type load curve

π_{ji} : Part of the j -th customer-type fed by the i^{th} network-type
 $T_i(t)$: Load curve of the i^{th} network-type
 $C_j(t)$: Load curve of the j^{th} customer-type

Solving the formulated optimization problem, all “ π_s ” will be determined, guaranteeing that all customer-types will be associated with network-types, thus indicating how customers will combine to form load curves of network-types.

To find responsibilities of each customer -type in the energy delivery costs of each voltage level, it is necessary, besides knowing the formation of each network-type typology, the contribution factor of each customer-type on the peak-load points for each network-type load curve.

Equation 2 presents the definition of a customer-type responsibility in the peak hours of the network-types that feed the voltage level in which the customer-type is connected. A peak hour point occurs when hourly demand of a load curve reaches at least 90% of the observed maximum demand.

$$R_{ji}^e = \pi_{ji} \cdot \frac{\sum_{h \in Np_i} Cf_{ji}(h)}{Np_i} \quad (2)$$

Where

R_{ji}^e : Responsibility of customer-type j in network-type i at the voltage level e
 $Cf_{ji}(h)$: Contribution factor of customer-type j at the peak hour h of network-type i ($Cf_{ji}(h) = \text{Demand}(h) / \text{Maximum Demand}$)
 Np_i : Number of peak hour points found in the i^{th} network-type.

The customer-type’s responsibility on the whole level of voltage “ e ” is defined in equation 3.

$$R_j^e = \sum_i R_{ji}^e \quad (3)$$

The capacity cost of the j^{th} customer-type on the level of voltage e is defined in equation 4.

$$Cap_j^e = R_j^e \cdot LTMC^e \cdot TCA_j^e \quad (4)$$

Where

$LTMC^e$: Long term marginal cost for level e
 TCA_j^e : Technical coefficient of attendance to customer-type j by the voltage level e .

The technical coefficient of attendance is a simple coefficient that indicates the percentage of load power delivered to the j^{th} customer-type by the e^{th} voltage level. In a simple cascade distribution system with no power

injections, all TCA_s are equal to 1.

Finally, it is necessary to normalize the calculated capacity costs to impose the average capacity cost at each level of voltage equal to the correspondent voltage level long term marginal cost. Since responsibilities, as defined previously, vary from a real range between 0 and 1, the weighted average capacity cost considering the aggregate demand of the e^{th} voltage level will be different from the long term marginal cost in that level. To solve this problem, a very simple adjustment factor will be required, given by:

$$WACap^e = LTMC^e = af^e \cdot \frac{\sum_{j=1}^{Nc} Cap_j^e \cdot D_j}{\sum_{j=1}^{Nc} D_j} \quad (5)$$

Where

$WACap^e$: Weighted average capacity cost of customer-types connected at level “ e ”
 af^e : Adjustment factor of the e^{th} voltage level
 D_j : Aggregate demand power of the j^{th} customer-type

CONCLUSIONS

This paper presented a method to determine a tariff structure that depends on customer’s load profiles and their interference on network’s load profiles in order to find out responsibilities on distribution system marginal costs. Although customers’ elasticity of demand was not taken into account due to empirical difficulties, the proposed method has shown efficiency and simplicity in designing a tariff structure regardless of the value of the permitted revenue in a price-cap regulation model.

REFERENCES

- [1] J. C. L Pires; M. S. Piccinini, 1998, “Modelos de regulação Tarifária do Setor Elétrico” - *Revista do BNDES*.
- [2] J.W. Marangon Lima et al, 2002, "Distribution Pricing Based on Yardstick Regulation", *IEEE Transactions on Power Systems*, VOL. 17, NO. 1, February, 2002.
- [3] H. Rudnick; J.A. Donoso, 2000, “Integration of Price Cap and Yardstick Competition Schemes in Electrical Distribution Regulation”, *IEEE Transactions on Power Systems*, Vol. 15, NO.4, November, 2000.
- [4] J. P. Nelson, M. J. Roberts, and E. P. Tromp, 1987, *An analysis of Ramsey pricing in electric utilities - Regulation Utilities in an Era of Deregulation*, M. A. Crew, Ed. London: Macmillan, 85-110.
- [5] D.M. Kreps, 2004, *Microeconomics for managers*, W.W. Norton & Company, New York, USA, 262-290.
- [6] A.U. Antunes et al, 2002, “Calculation of Marginal Costs in Distribution Networks: Present Tendencies and Critical Analysis”, *IEEE/PES T&D 2002 Latin America*.
- [7] G. Chico et al, 2006, “Comparisons Among Clustering Techniques for Electricity Customer Classification”, *IEEE Transactions on Power Systems*, VOL. 21, NO. 2, May, 2006.